

1928-1956 Pickup Truck Parts



1948-52 Ford pickup

### 1928-56 FORD REAR FENDERS-FIBERGLASS

- 1928-29 Specify L or R . . . . . each \$275.00
- 1930-31 For "narrow" 41-1/2" wide bed, L or R . . ea \$275.00
- 1930-31 For "wide" 46" wide bed, L or R . . . . . each \$275.00
- 1932 Pickup, Panel station wagon, L or R . . . each \$275.00
- 1933-34 Pickup, Panel, L or R . . . . . each \$275.00
- 1935-37 Pick-up, L or R . . . . . each \$475.00
- 1938-41 Pick-up, L or R . . . . . each \$500.00
- 1942-47 Pick-up, L or R . . . . . each \$500.00
- 1948-50 Pick-up, L or R . . . . . each \$500.00
- 1951-52 Pick-up, L or R . . . . . each \$500.00
- 1953-56 Pick-up, Stamped steel, L or R . . . . . each \$400.00



1948-50 Ford pickup

### WESCOTT 1928-56 FORD PICKUP FRONT FENDERS -FIBERGLASS

- 1928-29 specify early or late style, L or R . . . . . each \$390.00
- 1930-31 specify 30 or 31 style, L or R . . . . . each \$390.00
- 1932 Front fender, specify L or R . . . . . each \$390.00
- 1933-34 Front fender, specify L or R . . . . . each \$390.00
- 1935-37 Front fender, specify L or R . . . . . each \$500.00
- 1938-39 Front fender, specify L or R . . . . . each \$500.00
- 1938-39 Lower grille extension, specify L or R . . . each \$500.00
- 1940-41 Front fender, specify L or R . . . . . each \$500.00
- 1942-47 N/A . . . . .
- 1948-50 Front fender, specify L or R . . . . . each \$525.00
- 1948-50 Front fender extension, specify L or R . . . each \$250.00
- 1951-52 Front fender, specify L or R . . . . . each \$525.00
- 1951-52 Front fender extension, specify L or R . . . each \$175.00
- 1953-56 Steel, specify L or R . . . . . each \$475.00



1940-41 Ford pickup

### 1928-56 FORD PICKUP INNER FRONT FENDERS

- 1935-36 Inner front fender, fiberglass . . . . . each \$130.00
- 1937 Inner front fender, fiberglass . . . . . each \$130.00
- 1938-39 Inner front fenders, fiberglass . . . . . each \$175.00
- 1940-41 Inner front fenders, . . . . . pair \$325.00
- 1940-41 Inner front fenders, Bitchin Steel . . . . . pair \$350.00
- 1940-41 Inner front fenders, fiberglass . . . . . each \$225.00
- 1953-56 Inner front fenders, Steel . . . . . each \$375.00





1938-39 Ford Pickup  
Rear Fender Brace



1940-41 Ford Pickup  
Front Fender Brace

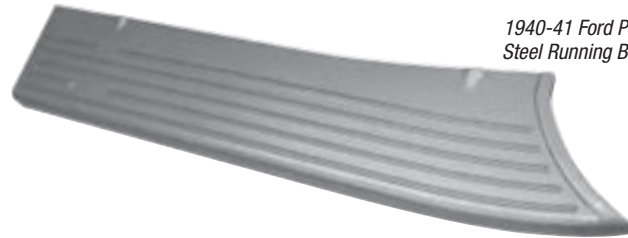

1940-41 Ford Pickup  
Steel Running Boards

## FENDER BRACES

<b>B-16025</b>	1932 Front, L or R.....each	<b>\$45.00</b>
<b>40-16025</b>	1933-34 Front, .....pair	<b>\$125.00</b>
<b>40-16094</b>	1933-34 Rear front, L or R.....each	<b>\$30.00</b>
<b>50-16094</b>	1935-37 Front fender skirt brace.....each	<b>\$30.00</b>
<b>50-16391</b>	1935-37 Rear fender, L or R.....each	<b>\$30.50</b>
<b>81C-16094</b>	1938-39 Front, L or R.....each	<b>\$30.00</b>
<b>81C-16391</b>	1938-41 Rear L or R.....each	<b>\$30.00</b>
<b>91A-16088/9</b>	1940-41 Front, L or R, .....pair	<b>\$30.00</b>
<b>BAAA-16010</b>	1953-56 Front fender, L or R.....each	<b>\$30.00</b>
<b>BAAA-16148</b>	1953-56 Front fender to cowl, L or R...each	<b>\$30.00</b>
<b>BAAA-16340A</b>	1953-56 Rear fender bracket, L or R...each	<b>\$30.00</b>



1933-34 Ford pickup  
Splash Apron

## 1928-56 FORD PICKUP SPLASH APRONS

<b>FSA2829A</b>	1928-28 Stock style, fiberglass.....each	<b>\$120.00</b>
<b>FSA3031A</b>	1930-31 Stock style, fiberglass.....each	<b>\$120.00</b>
<b>A-16527-B</b>	1930-31 Stock style, steel.....each	<b>\$67.50</b>
<b>FSA32A</b>	1932 Stock style, fiberglass.....each	<b>\$120.00</b>
<b>B-16527</b>	1932 Stock style, steel.....each	<b>\$40.00</b>
<b>FSA3334PU</b>	1933-34 Stock style, fiberglass.....each	<b>\$120.00</b>
<b>GSP35PU</b>	1935 Grille inner apron, fiberglass....each	<b>\$100.00</b>
<b>FSB36PU</b>	1936-37 Grille lower shield, fiberglass..each	<b>\$125.00</b>
<b>7C-8188</b>	1948-50 Under grille panel, steel.....each	<b>\$225.00</b>
<b>B3C-8188-A</b>	1953 Under grille panel, fiberglass....each	<b>\$250.00</b>
<b>B4C-8188-A</b>	1954 Under grille panel, fiberglass.....each	<b>\$250.00</b>
<b>B6C-8188-A</b>	1955-56 Under grille panel, fiberglass..each	<b>\$250.00</b>
<b>BAAA-8311</b>	1953-55 Air deflector, steel, L or R....each	<b>\$120.00</b>
<b>BAAA-8310</b>	1956 Air deflector, steel, L or R.....each	<b>\$80.00</b>



## LOWER BED SIDE PANELS

Stamped steel panel fills space between box and running boards in front of rear fenders.

<b>10296-L/R</b>	1935-37 Left or right.....each	<b>\$30.00</b>
<b>10298-L/R</b>	1938-41 Left or right.....each	<b>\$26.00</b>
<b>10300-L/R</b>	1942-47 Left or right.....each	<b>\$26.00</b>

## 1928-56 FORD PICKUP STEEL RUNNING BOARDS

Quality, all-steel boards with all the original details and construction. Heavy gauge, die-formed steel with underside bracing. Most are available smooth or with the exact ribbed top pattern.

<b>A-16450-A</b>	1928-29 Steel, with rubber cover.....pair	<b>\$225.00</b>
<b>A-16450-APU</b>	1928-29 Steel, commercial style with stamped diamond plate.....pair	<b>\$225.00</b>
<b>A-16450-A</b>	1928-29 Steel, smooth.....pair	<b>\$199.00</b>
<b>5A2829A</b>	1928-29 Running board splash aprons fiberglass, L or R.....each	<b>\$185.00</b>
<b>A-16450-BO</b>	1930 Steel, with rubber cover.....pair	<b>\$225.00</b>
<b>A-16450-CM</b>	1931 Steel, with rubber cover.....pair	<b>\$425.00</b>
<b>A-16450-BPU</b>	1930-31 Steel, commercial style with stamped diamond plate.....pair	<b>\$225.00</b>
<b>A-16450-CSM</b>	1930-31 Steel, smooth.....pair	<b>\$199.00</b>
<b>5A31A</b>	1930 Running board splash aprons stamped steel.....pair	<b>\$345.00</b>
<b>5A31A</b>	1931 Running board splash aprons fiberglass, L or R.....each	<b>\$350.00</b>
<b>B-16450-S</b>	1932 Steel, with rubber cover.....pair	<b>\$895.00</b>
<b>B-16450-SM</b>	1932 Steel, smooth.....pair	<b>\$525.00</b>
<b>46-16450-S</b>	1933-34 Steel, w/stock diamond plate..pair	<b>\$375.00</b>
<b>46-16450-SM</b>	1933-34 Steel, smooth.....pair	<b>\$300.00</b>
<b>50-16450/1</b>	1935-37 RH & LH.....pair	<b>\$895.00</b>
<b>81C-16450/1</b>	1938-39 RH & LH.....pair	<b>\$895.00</b>
<b>01C-16450/1</b>	1940-41 RH & LH.....pair	<b>\$700.00</b>
<b>1C-16450-S</b>	1948-52 steel, w/stock ribs.....pair	<b>\$895.00</b>
<b>1C-16450-SM</b>	1948-52 steel, smooth, no ribs.....pair	<b>\$595.00</b>
<b>BAAA-16450-PR</b>	1953-56 steel, w/stock ribs.....pair	<b>\$595.00</b>



## FIBERGLASS RUNNING BOARDS

Heavy fiberglass replicas of original running boards with rubber cover detail molded in.

<b>RB3537PU</b>	1935-37 fiberglass, w/stock ribs, L or R..ea	<b>\$450.00</b>
<b>RB3839PU</b>	1938-39 fiberglass, w/stock ribs, L or R..ea	<b>\$450.00</b>
<b>RB4041PU</b>	1940-41 fiberglass, w/stock ribs, L or R..ea	<b>\$450.00</b>

1928-1956 Pickup Truck Parts

## FIREWALLS AND FLOORS- BITCHIN' PRODUCTS & DIRECT SHEET METAL



1948-52 Ford Pickup



1948-52 Ford Pickup  
Mid-Floor Section



1947-55 Chevy Pickup

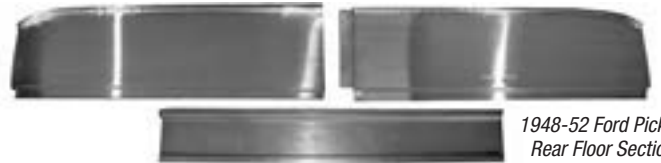

1948-52 Ford Pickup  
Rear Floor Section

### BITCHIN' PRODUCTS FLOORBOARD KITS

Floorboard kits are made to fit with minimum trimming and will give a solid base to mount your seats. There is adequate clearance for the GM Turbo 350/400 series transmissions and kits include all sheet metal parts, hardware, instructions and body sealer needed to complete installation in a professional manner.

#### FORD FRONT FLOOR KITS

281005	1928-31 Front floor kit . . . . .	\$195.00
321003	1932 Front floor specify firewall . . . . .	\$325.00
351002	1933-39 Front floor . . . . .	\$350.00
401002	1940-47 Front floor . . . . .	\$350.00
481000	1948-52 Front floor small, big block . . . . .	\$350.00
531322	1953-55 Front floor stock replacement, R ea	\$100.00
531323	1953-55 Front floor stock replacement, L ea	\$100.00
531324	1956 Front floor stock replacement, R ea . . .	\$100.00
531225	1956 Front floor stock replacement, L ea . . .	\$100.00

#### CHEVY FRONT FLOOR KITS

751002	1947-55 Front floor for stock firewall . . . . .	\$365.00
751003	1947-55 Front floor for bitchin firewall . . . . .	\$365.00
752115	1955-59 Front floor . . . . .	\$430.00

### BITCHIN' PRODUCTS REAR FLOORBOARD KITS

#### FORD REAR FLOOR KITS

281056	1928-31 Closed Cab P.U. rear floor . . . . .	\$270.00
481036	1948-52 Rear floor kit . . . . .	\$114.00
531225	1953-56 Rear floor stock replacement ea	\$199.00

#### CHEVY REAR FLOOR KITS

751004	1947-55 Rear floor kit . . . . .	\$210.00
--------	----------------------------------	----------



1948-52 Ford Pickup Front Floor Section



1955 Chevy Pickup Rear Floor Section

### BITCHIN' PRODUCTS FIREWALLS

FORD PICKUPS	small block (set back)	big block (set back)
1928-29	281000 (4") . . . \$350.00	
1930-31	301005 (2.5") . \$350.00	301000 (4.5") . . . \$450.00
1932	321040 (2.75") \$430.00	321042 (5") . . . . \$450.00
1933-34	331000 . . . . . \$430.00	t
1935-36	351000 (3") . . . \$430.00	
1937-39	371000 (3") . . . \$430.00	
1940-47	401000 (2") . . . \$350.00	
1948-52	481000 (3") . . . \$375.00	

#### CHEVY PICKUPS

1947-55	751000 (3") . . . \$425.00	small or big block
1955-59	752100 (4") . . . \$525.00	small or big block

### TECHNICAL INFORMATION

The set back information provided is for reference only. The descriptions are intended to help you to determine which firewall kit will best fit your application. Be sure to check all measurements before ordering your kit. There are many factors which will affect your choice, engine setback, radiator core thickness, air conditioning or superchargers. If you have any questions, please call.

1928-1956 Pickup Truck Parts

1937 Ford Pickup

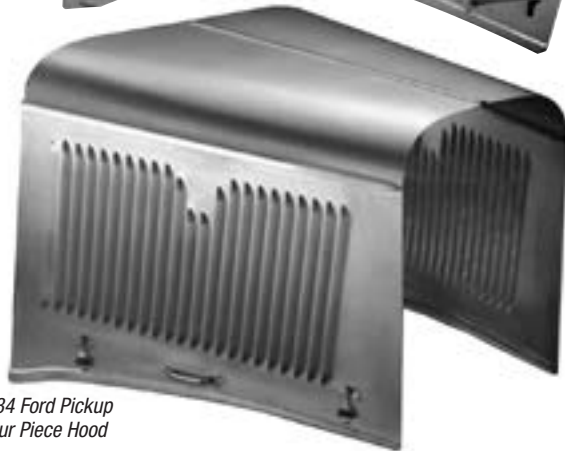

1934 Ford Pickup  
Four Piece Hood

### STEEL HOODS BY ROOTLIEB.

Sold as a complete four piece kit with stock style side panels. Two piece hood tops include center hinge strip, side panels include hood handles, latch clips, and hinge rods. Also available with a one piece top. Three piece hood panels do not include any hardware. Hood tops are available smooth or louvered, Sides are available stock, smooth, with one or two scoops or with 3 or 4 row hot rod louver pattern. Please call.

**FORD PICKUP HOODS** Complete stock style four piece hood with original louvers. One piece top, many other options available

- 1928-29, '32 style center strip ..... kit
- 1930-31, '32 style center strip ..... kit
- 1932-34 .....kit
- 1935-37.....kit

**PLEASE CALL FOR PRICES ON ALL HOODS.**



### WESTCOTT HOODS.

One piece fiberglass with internal steel cage. Hood latch and hinges mount to steel structure.

HD4041PU 1940-41 Ford Pickup fiberglass.....ea \$1175.00



3537FCC



4047FCBM



4852CM

### COWL PATCH REPAIR PANELS

#### 1928-56 FORD PICKUP

A-114-A	1928-29	pair	\$100.00
A-114-B	1930-31	pair	\$22.50
B-814	1932-34	pair	\$60.00
3537FCC	1935-37	pair	\$150.00
3839FCC	1938-39	pair	\$165.00
4047FCC	1940-41	pair	\$150.00
4047FCBM	1940-47 Front cab mount	pair	\$75.00
4047HP	1940-47 Lower door hinge post	pair	\$50.00
4852FCC-L	1948-52-Drivers side	each	\$55.00
4852FCC-R	1948-52-Pass. side	each	\$55.00
4852DHP	1948-52 Lower door hinge post	pair	\$50.00
4852FCM	1948-52 Cowl Inner-front cab mounts	pair	\$45.00
BAAA-8102054-PR	1953-56	pair	\$100.00

4852DHP



3537RCC



### QUARTER PATCH-CAB CORNER REPAIR PANELS

#### 1928-56 FORD PICKUP

A-1051-A	1928-29 Rear body Corner, L or R	each	\$45.50
A-870-B	1930-31 Rear body Corner, L or R	each	\$45.00
B-870	1932-34	pair	\$90.00
3537RCC	1935-37	pair	\$203.00
4047RCC	1940-41	pair	\$203.00
7C-8140302-PR	1948-52	pair	\$90.00
BAAA-8140302-PR	1953-56	pair	\$100.00



1928-1956 Pickup Truck Parts

1928-1956 Pickup Truck Parts



**DOOR BOTTOM REPAIR PANELS**

**1928-1956 FORD PICKUP CALL FOR AVAILABILITY**

281419	1928-29	..... pair	<b>\$41.00</b>
A-436-B	1930-31 6" tall.	..... pair	<b>\$50.00</b>
A-436-IB	1930-31 Inner panel	..... pair	<b>\$50.00</b>
B-836	1932-34 Pick-up, outer	..... pair	<b>\$65.00</b>
B-836-I	1932-34 Pick-up, inner door bottoms	.. pair	<b>\$45.00</b>
35370DSK	1935-37 Outer door skin	..... pair	<b>\$75.00</b>
3537IDBOT	1935-37 Inner door bottoms	..... pair	<b>\$85.00</b>
38470DSK	1938-47 Outer door skin	..... pair	<b>\$75.00</b>
01C-836	1938-47 Outer door skin	..... pair	<b>\$95.00</b>
3847IDBOT	1938-47 Inner door bottoms	..... pair	<b>\$95.00</b>
BAAA-8120200	1953-56 Outer door skin	..... pair	<b>\$130.00</b>
BAAA-8120120	1953-56 Inner door panels	..... pair	<b>\$90.00</b>



**ROCKER REPAIR PANELS**

**1928-1956 FORD PICKUP**

3537RP	1935-37	..... pair	<b>\$130.00</b>
4047RP	1940-47	..... pair	<b>\$75.00</b>
4852RP	1948-52	..... pair	<b>\$75.00</b>
BAAA-8110110	1953-56	..... pair	<b>\$100.00</b>



**LOWER REAR CAB PANELS**

**1928-1956 FORD PICKUP** - repairs across rear bottom of cab

A-877-A	1928-29 Roadster pickup	..... each	<b>\$225.00</b>
A-977-L	1928-29 Closed cab pickup	..... each	<b>\$225.00</b>
A-850-B	1930-31	..... each	<b>\$75.00</b>
B-850	1932-34	..... each	<b>\$75.00</b>
3537LRCP	1935-37	..... each	<b>\$80.00</b>
4047LRCP	1940-47	..... each	<b>\$80.00</b>



**TAILGATE PARTS**

TM-109	1938-50 Tailgate chain	.....	<b>\$65.00</b>
	Includes chain & cover, hook, bed mount bracket and latching link.		
10310	Inside latch	.....	<b>\$65.00</b>



**CAB MOUNTING WOOD**

88033	1932-34 Oak kit	.....	<b>\$135.00</b>
88034	1935-37 Hardwood kit	.....	<b>\$175.00</b>
	All holes drilled. Set of two. Also sometimes used on 1938-41.		
88036	1938-41 Hardwood Cab Mounting Blocks	..	<b>\$155.00</b>
	Six piece set. Some cabs originally came with two long blocks and some came with these six short blocks. These work for both types.		

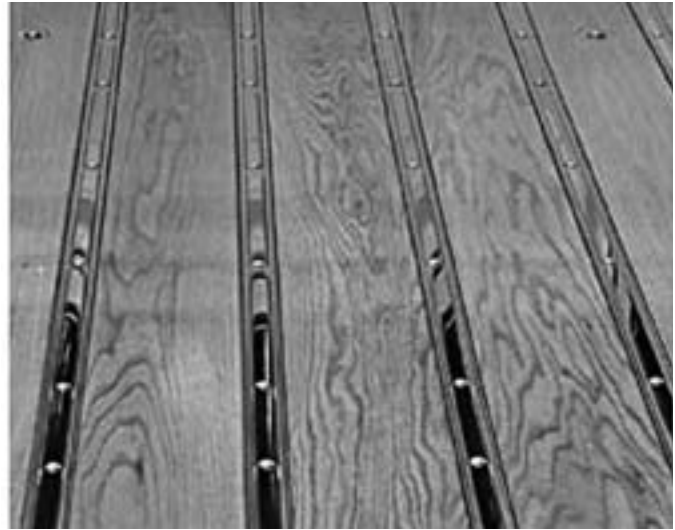

**CUSTOM BED WOOD KITS**

For all late 1931-50 Fords. An alternative kit to replace steel bed floor. Kit includes oak wood, steel strips, special spacers, bolts and brackets which make it appear to be factory.

Wood floor kit	.....	<b>\$449.00</b>
Wood floor kit with stainless steel strips	...	<b>\$449.00</b>

The stainless steel strips come without mounting holes and are easily drilled and cut to length. Square punching is available at \$2.00 per strip. Please provide your hole location measurements.



**TAILGATE PARTS**

10315	1938-50 Tailgate end, Cast iron Primed	....	<b>\$15.00</b>
10215	Late 1931-36 Tailgate hinge	.....	<b>\$8.95</b>
	Stamped steel. Primed. All holes drilled. (Three required per truck.) B78446		
10216	1937-52 Tailgate hinge	.....	<b>\$10.00</b>
	Stamped Steel. All holes drilled. Primed. 81C830860		
	Stainless	.....	<b>\$20.00</b>

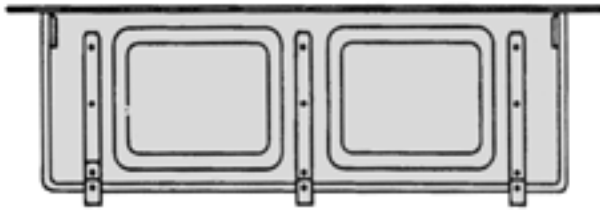

**1931-34 FORD TAILGATE with Hinge Straps**  
46-3/4" wide- outer lip to outer lip

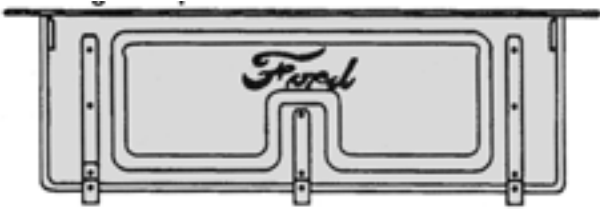

**1935-36 FORD TAILGATE with Hinge Straps**  
46-3/4" wide- outer lip to outer lip



**1937 FORD TAILGATE**  
46-3/4" wide- outer lip to outer lip

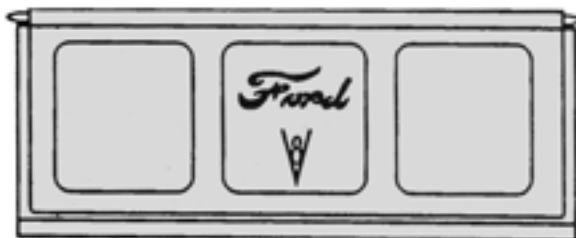

**1938-40 FORD TAILGATE**  
46-3/4" wide- outer lip to outer lip. 81C-830700



## FORD REPRODUCTION TAILGATES

Available for 1926 to 72 Ford and 1947-59 Chevy trucks. All die stamped steel with all the details of the original. Primed and ready to finish.

10137	1931-34 Ford .....	\$315.50
10138	1935-36 Ford .....	\$295.50
10139	1937 Ford .....	\$295.50
10140	1938-40 Ford .....	\$295.50
10141	1941 Ford .....	\$295.50
10142	1942-50 Ford .....	\$295.50
10143	1950-52 Ford .....	\$295.50
10144	1953-72 Ford .....	\$395.50
	1947-59 Chevy/GMC .....	starting at \$265.00



**1941 FORD TAILGATE**  
46-3/4" wide- outer lip to outer lip. 11C-40700



**1942-50 FORD TAILGATE**  
49-3/4" wide- outer lip to outer lip. 21C-8340700



**1950-52 FORD TAILGATE**  
49-3/4" wide- outer lip to outer lip. 8C-40700



**1953-72 FORD TAILGATE**  
50" wide- outer lip to outer lip. B7C-8340700A  
(Dennis Carpenter)

1928-1956 Pickup Truck Parts

## FORD 1/2 TON REPRODUCTION BED SIDES

Available for 1926 to 56 Ford trucks. All bed sides are die stamped steel with all the details of the original. Primed and ready to finish. Available with or without stake holes. Stake pockets are not included

### 1928-37 BED SIDES

10101	1928-31 LH (61" long)	Call for prices
10102	1928-31 RH (61" long)	Call for prices
10103	1931 Wide bed LH	\$349.00
10104	1931 Wide bed RH	\$349.00
10105	1932 LH	\$349.00
10106	1932 RH	\$349.00
10107	1932 LH short*	\$349.00
10108	1932 RH short*	\$349.00
10109	1933-34 LH	\$349.00
10110	1933-34	\$349.00
10111	1933-34 LH short*	\$349.00
10112	1933-34 RH short*	\$349.00
10113	1935-36 LH	\$349.00
10114	1935-36 RH	\$349.00
10115	1937 LH	\$349.00
10116	1937 RH	\$349.00

\* 1932 Short- 55" long, 1933-34 Short- 60" long

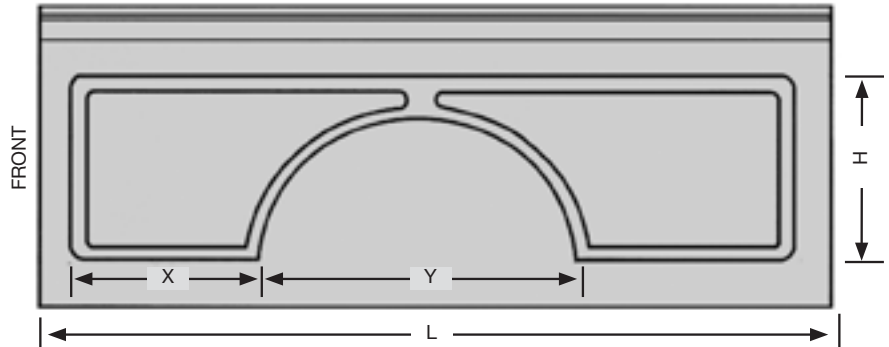

YEAR	X	Y	L	H
1928-31	4.0"	27.0"	56.5"	8.0"
1931 Wide bed	4.0"	31.0"	61.0"	12.0"
1932	4.0"	34.5"	65.5"	16.5"
1933-34	9.0"	34.5"	70.5"	16.5"
1936-36 #50-830500 16"	16.0"	37.0"	70.5"	16.5"
1937	16.0"	37.0"	74.5"	16.5"

All panels also have the correct stamped design in the wheel opening (approximately where the "Y" is located in the above drawing).

### 1938-50 BED SIDES

10117	1938-47 LH	\$349.00
10118	1938-47 RH	\$349.00
10121	1948-50 LH	\$349.00
10122	1948-50 LH	\$349.00

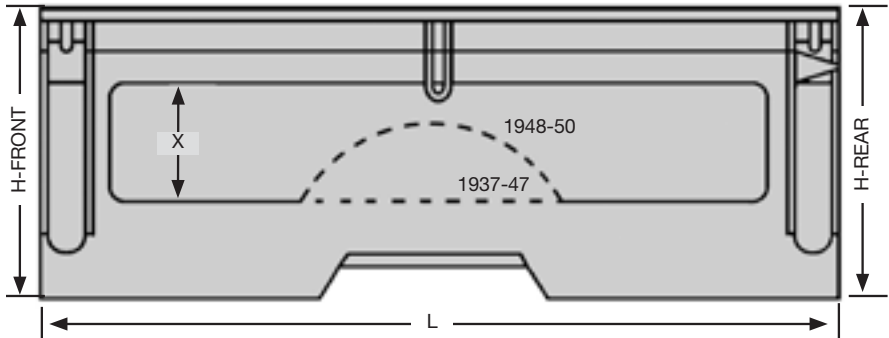

YEAR	H-FRONT	H-REAR	L	X	BOX WIDTH
1938-41 #81C830500	25.25"	25.25"	78.75"	12.0"	46.0"
1942-47 #81C830500	25.25"	25.25"	78.75"	12.0"	49.0"
1948-50	27.00"	25.25"	78.75"	12.0"	49.0"

### 1951-56 BED SIDES

10123	1951-52 LH	\$278.00
10124	1951-52 RH	\$278.00
10125	1953-72 LH	\$278.00
10126	1953-72 RH	\$278.00

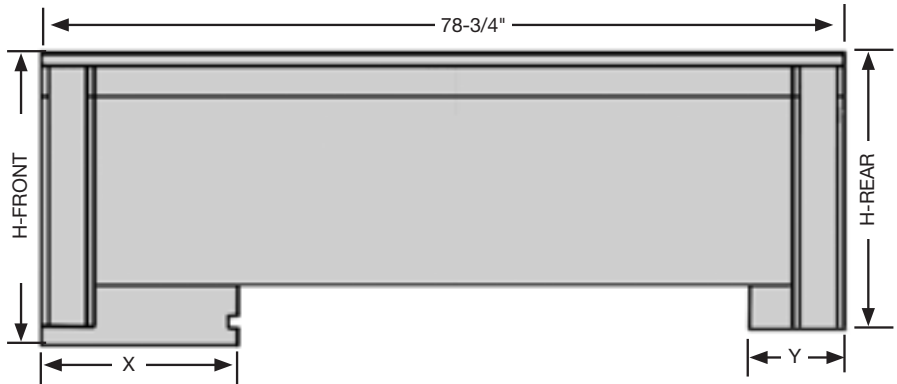

YEAR	H-FRONT	H-REAR	Y	X	BOX WIDTH
1951-52	27.75"	25.25"	5.50"	17.50"	49.0"
1953-72	27.75"	25.25"	8.25"	15.75"	49.0"

1928-1956 Pickup Truck Parts



### COMPLETE UN-ASSEMBLED BED KITS-FORD

11113/1	1931 Wide bed .....	\$2,995.00
11115/1	1932 1/2 Ton (short version available) .....	\$2,995.00
11117/1	1933-34 1/2 Ton (short version available) .....	\$2,995.00
11119/1, 11121/1	1935-36, 1937 .....	\$2,995.00
11123/1, 11121/1	1938-40, 1941 .....	\$2,995.00
11127/1, 11129/1	1942-47, 1948-50 .....	\$2,995.00
11131/1, 11133/1	1950-52, 1953-72 .....	\$2,000.00

### CHEVY/GMC

44113/3	1933-36 Smooth or Chevy tailgate .....	\$2,495.00
44115/3	1937-39 Smooth or Chevy tailgate .....	\$2,495.00
44117/3	1940 Smooth or Chevy tailgate .....	\$2,495.00
44119/3	1941-46 Smooth tailgate .....	\$2,495.00
44121/3	1947-50 Chevy or GMC tailgate .....	\$2,495.00
44121/3	1951-53 Chevy or GMC tailgate .....	\$2,495.00

Note: Chevy/GMC kits do not include bed wood.

### COMPLETE PICKUP BED KITS

This is a complete kit with everything you need to assemble a new bed. Made of 16 gauge steel. Fender holes are not pre-drilled but everything is pre-fit to help assembly. Fenders are not included. Also available assembled.

#### Parts Included in kit -

- Front Bed Panel
- Pair of Bedside Assemblies
- Complete Sub-frame
- Tailgate - Now Available
- Pair Tailgate Chains
- Pair Tailgate Hinges
- Floor Adapter kit
- Set of Bed wood
- Set of Steel Strips
- Cap Strip for Back Edge of Floor

- Complete Bed Assembly Bolt Kit includes Fender Bolts & Rivets
- Pair of Lower Bed Extension Panels

#### Stainless options -

- Stainless Strips - add \$120.00
- Stainless Cap Strip - add \$25.00
- Stainless Strip Bolts - add \$35.00
- Stainless Bed Mount Kit - add \$45.00

1931-50 Ford complete assembled bed .....	\$3,495.00
1950-52 Ford complete assembled bed .....	\$3,495.00
1953-72 Ford complete assembled bed .....	\$3,495.00
1934-53 Chevy/GMC complete assembled bed .....	\$2,895.00
Crating charge for kit .....	\$150.00
Crating charge for assembled bed .....	\$200.00

### 1928-37 FORD PICKUP PARTS

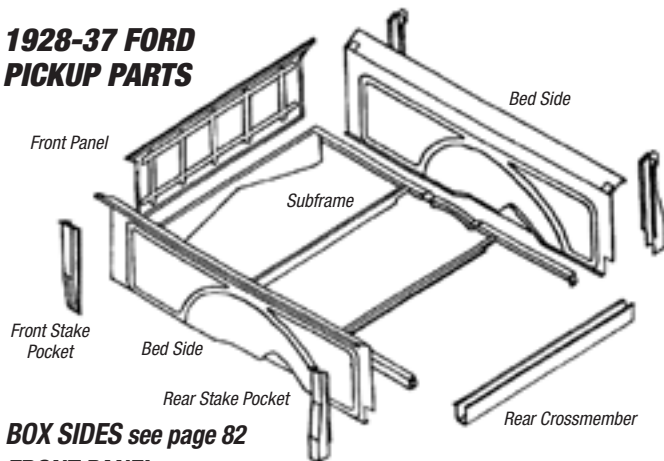

BOX SIDES see page 82

#### FRONT PANEL

10755	1928-31 .....	each \$92.00
10756	1931 Wide bed .....	each \$215.00
10757	1932-37 .....	each \$199.00

#### STAKE POCKETS

10267	1926-31 Front .....	each \$34.00
10268, 10269	1931-37 Front, rear .....	each \$34.00

#### CROSSMEMBERS

22001	1928-31 .....	each \$30.00
22002	1931 Wide bed .....	each \$65.00
22004	1932 .....	each \$65.00
22007	1933-34 .....	each \$65.00

#### REAR CROSSMEMBER

20336	1931 Wide Bed .....	each \$72.00
20337	1932-37 .....	each \$70.00

#### SIDE SUB-RAILS

1928-37 Left or Right .....	each \$125.00
-----------------------------	---------------

### 1938-56 FORD PICKUP PARTS

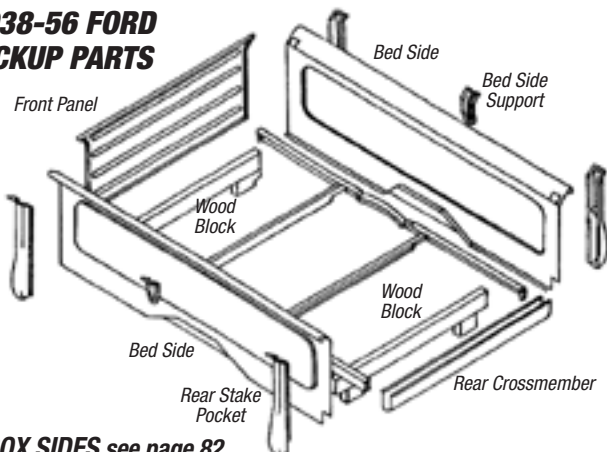

BOX SIDES see page 82

#### FRONT PANEL

10758	1938-41 .....	each \$195.00
10759	1942-50 .....	each \$150.00
10760	1950-72 .....	each \$150.00

#### STAKE POCKETS

10270	1938-50 Front and rear same .....	each \$30.00
10271	1950-72 Front and rear same .....	each \$24.00

#### FRONT & CENTER CROSSMEMBER

22011	1935-41 .....	each \$75.00
22015	1942-50 .....	each \$75.00
22018	1950-72 .....	each \$50.00

#### REAR CROSSMEMBER

20338	1938-41 .....	each \$ 60.00
20339	1942-50 .....	each \$ 80.00
20340	1951-72 .....	each \$ 80.00

#### SIDE SUB-RAILS

1938-50 .....	each \$125.00
---------------	---------------

#### BED SIDE SUPPORT

10304	1937-50 Left or right .....	each \$17.00
-------	-----------------------------	--------------

Call 402.886.2275 or click: [www.heinzmanstreetrods.com](http://www.heinzmanstreetrods.com)

1928-1956 Pickup Truck Parts